



The importance of Metrology in Wireless Communication Systems

From AM/FM to SDR Systems

Nuno Borges Carvalho
nbcarvalho@ua.pt
www.av.it.pt/nbcarvalho
Universidade de Aveiro

INSTITUÇÕES ASSOCIADAS



instituto de
telecomunicações

creating and sharing knowledge for telecommunications

Presentation Outline

1. Introduction
2. Typical Instrumentation
3. The Role of Signal Excitation
4. Software Defined Radio Schemes
5. Some Real World Applications

INSTITUÇÕES ASSOCIADAS
universidade
de aveiro



1. Introduction



Wireless Systems, started with Tesla, Maxwell, Henry, Marconi, Armstrong, ...
With the born of these new technology, metrology for this type of systems immediately start to emerge, since the knowledge of physical properties of the radio was fundamental for the correct implementation of those systems.

*Metrology is defined by the International Bureau of Weights and Measures (BIPM)
"the science of measurement, embracing both experimental and theoretical determinations at any level of uncertainty in any field of science and technology."*

1. Introduction

Wireless Communications has started a long time ago, with the broadcast radio been one of the more massive implantation.

At that time metrology for wireless (radio) applications, mainly addressed the transmitted power.

- Transmitted power;
- Signal Quality measured mainly using human ear;



1. Introduction

Other specific measurements were needed for example for radar, the pulse width, the reflection coefficient of the load, was also a very important problem due mainly to the huge transmitted power.



1. Introduction

With the increase in radio transmissions, the spectrum start to be full, increasing the need for extremely good metrology systems, that can support the income of national agencies.



With the increase number of systems, measurements as:

- RF Bandwidth
- SNR, SIR, etc....

1. Introduction

With the advent of mobile communications, the metrology starts to be more demanding:

- Doppler Effects
- SNR
- Intermodulation



universidade
de aveiro

7

Music While Walking With Radio

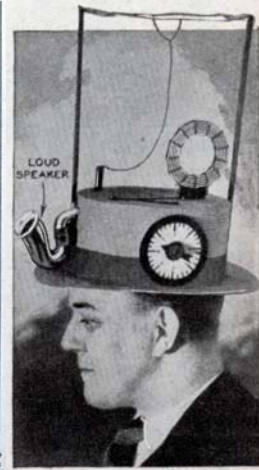

"Calling Herbert Mundin to stage 6"—messages such as these are radioed to this actor as he works on movie lot.

it Instituto de telecomunicações

1. Introduction

Next step on wireless communications and thus consequently on metrology was the advent of digital communications.

- Error Vector Magnitude
- Bit Error Rate
- Intermodulation

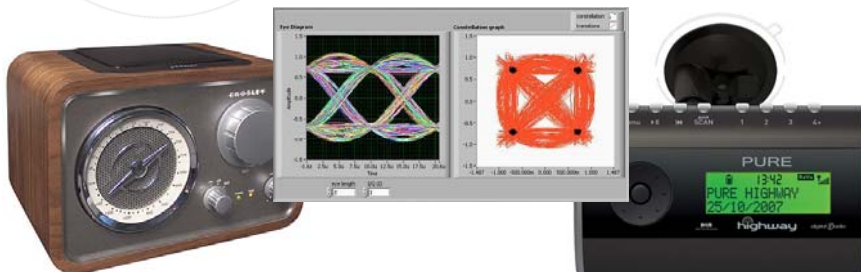

INSTITUÇÕES ASSOCIADAS
universidade
de aveiro

8

it Instituto de telecomunicações

1. Introduction

This measurement procedure can also move to higher levels of abstraction using QoS measurement systems.

Measure the complete QoS
Measure network parameters



1. Introduction

Nowadays metrology has a strong impact on everyday communications, since it is fundamental and key to:

- Researchers
- Communication Operators
- Policy standard bodies
- Non human devices
- ...



Presentation Outline

1. Introduction
2. Typical Instrumentation
3. The Role of Signal Excitation
4. Software Defined Radio Schemes
5. Some Real World Applications

2. Typical Instrumentation

Typical Instrumentation, spans from simple measurement of power to more complex schemes of complete demodulation of the signal and bit pattern evaluation. For instance some instruments are:

- Power Meters
- Spectrum Analyzers
- Network Analyzers
- Time domain scopes, oscilloscopes
- Noise Figure Meters
- Vector Signal Analyzers
- Protocol Analyzers
- ...

2. Typical Instrumentation

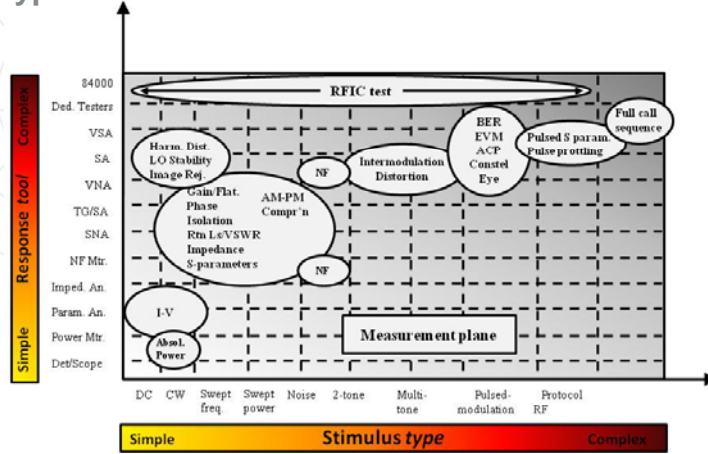

VSA – Vector Signal Analyzer, SA – Spectrum Analyzer, VNA – Vector Network Analyzer, TG/SA – Tracking Generator, SNA – Scalar NA, NF Mtr. – Noise Figure Meter, Imp. An. – Impedance Analyzer, Power Mtr. – Power Meter, Det. Scope – Diode Detector, Oscilloscope

2. Typical Instrumentation

Power can be achieved from:

$$p(t) = \frac{1}{T} \int_{-T/2}^{T/2} v(t)^2 dt$$

Power can be considered in an window interval or in a period if the signal is periodic .

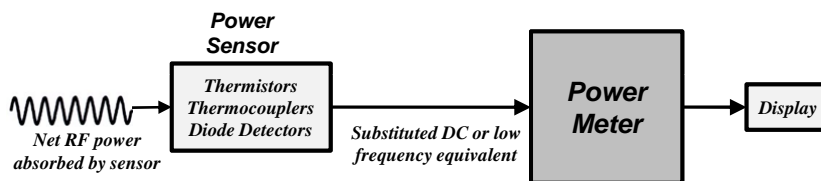

2. Typical Instrumentation

A diode detector can be represented by :

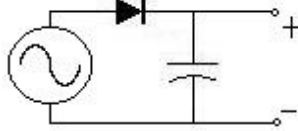

The output current will then be:

$$y(t) = I_s \left(e^{\frac{v}{V_T}} - 1 \right) \approx k_1 v(t) + k_2 v(t)^2 + \dots$$

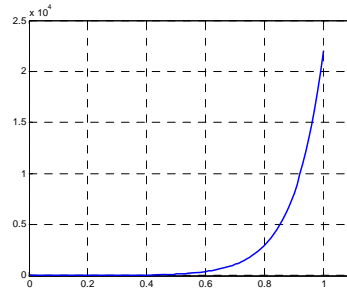

$$y(t) \approx k_1 A \sin(\omega t) + k_2 [A \sin(\omega t)]^2 = k_1 A \sin(\omega t) + k_2 \frac{A^2}{2} [\sin(2\omega t) + 1]$$

2. Typical Instrumentation

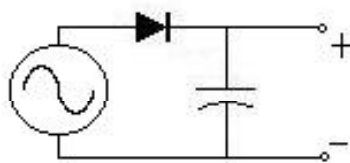

The output DC current will thus be:

$$y_{DC}(t) \approx k_2 \frac{A^2}{2}$$

2. Typical Instrumentation

From a practical point of view the DC curve is a nonlinear function of the device, thus it should be calibrated accordingly.

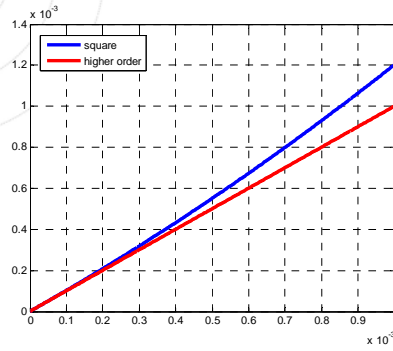

2. Typical Instrumentation

Calibration

is the process of establishing the relationship between a measuring device and the units of measure.

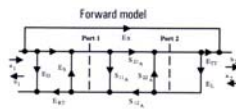

E_{1r} = fwd directivity E_{2t} = fwd load match
 E_{1t} = fwd source match E_{2r} = fwd transmission tracking
 E_{2r} = fwd reflection tracking E_{1t} = fwd isolation
 E_{1t} = rev directivity E_{2r} = rev load match
 E_{2t} = rev source match E_{1r} = rev transmission tracking
 E_{2r} = rev reflection tracking E_{1t} = rev isolation

- Each actual S-parameter is a function of all four measured S-parameters
- Analyzer must make forward and reverse sweep to update any one S-parameter
- Luckily, you don't need to know these equations to use network analyzers!!!

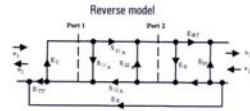

$$S_{11a} = \frac{S_{11m} - E_{1r} S_{21m} + E_{2r} S_{12m} - E_{1t} S_{22m} + E_{2t} S_{11m} - E_{1r} S_{21m}}{1 - S_{11m} - E_{1r} S_{21m} + E_{2r} S_{12m} - E_{1t} S_{22m} + E_{2t} S_{11m} - E_{1r} S_{21m}}$$

$$S_{12a} = \frac{S_{12m} - E_{1r} S_{21m} - S_{21m} + E_{2r} S_{12m} - E_{1t} S_{22m} + E_{2t} S_{11m} - E_{1r} S_{21m}}{1 - S_{11m} - E_{1r} S_{21m} + E_{2r} S_{12m} - E_{1t} S_{22m} + E_{2t} S_{11m} - E_{1r} S_{21m}}$$

$$S_{21a} = \frac{S_{21m} - E_{1r} S_{21m} - S_{12m} + E_{2r} S_{12m} - E_{1t} S_{22m} + E_{2t} S_{11m} - E_{1r} S_{21m}}{1 - S_{11m} - E_{1r} S_{21m} + E_{2r} S_{12m} - E_{1t} S_{22m} + E_{2t} S_{11m} - E_{1r} S_{21m}}$$

$$S_{22a} = \frac{S_{22m} - E_{1r} S_{21m} - S_{12m} + E_{2r} S_{12m} - E_{1t} S_{22m} + E_{2t} S_{11m} - E_{1r} S_{21m}}{1 - S_{11m} - E_{1r} S_{21m} + E_{2r} S_{12m} - E_{1t} S_{22m} + E_{2t} S_{11m} - E_{1r} S_{21m}}$$

2. Typical Instrumentation

Network Analyzer

- *S Parameters*
- *VSWR*
- *Gain (Amplitude and Phase)*
- *Bandwidth*
- *1dB Compression Point*
- *AM/AM and AM/PM*

Test Signal – Sine Wave

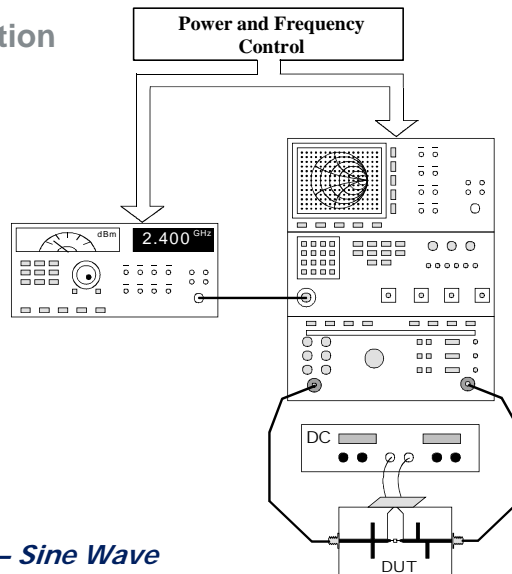

2. Typical Instrumentation

Spectrum Analyzer

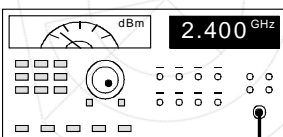

- *Gain (Amplitude)*
- *IMD*
- *Bandwidth*
- *IP3*
- *AM/AM*
- *ACPR*
- *1dB Compression*
- *NPR*

Test Signal:

- *Sine Wave*
- *Two-Tones*
- *Multisines*
- *Arbitrary Waveforms*

2. Typical Instrumentation

Spectrum Analyzer

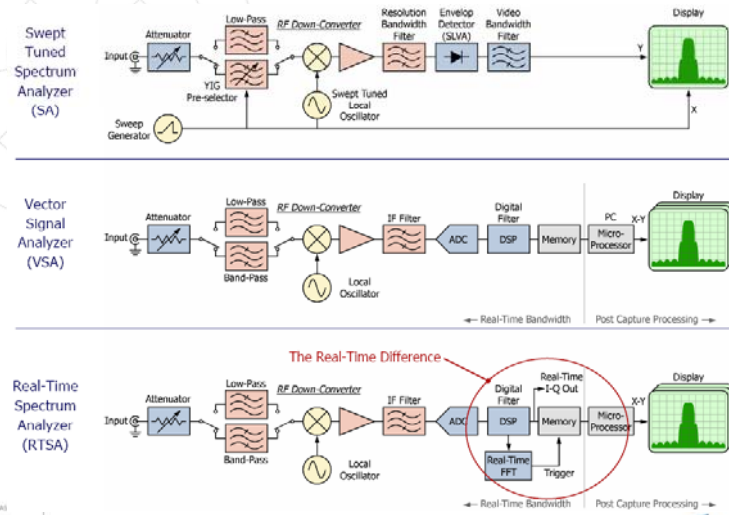

INSTITUÇÕES ASSOCIADAS
 Universidade de Aveiro

from tektronix

Instituto de telecomunicações

2. Typical Instrumentation

Oscilloscope – for analog domain

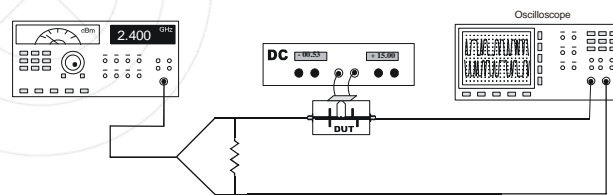

Allows simultaneous measurements of the input and output signals

INSTITUÇÕES ASSOCIADAS
 Universidade de Aveiro

Instituto de telecomunicações

2. Typical Instrumentation

Logic Analyzers

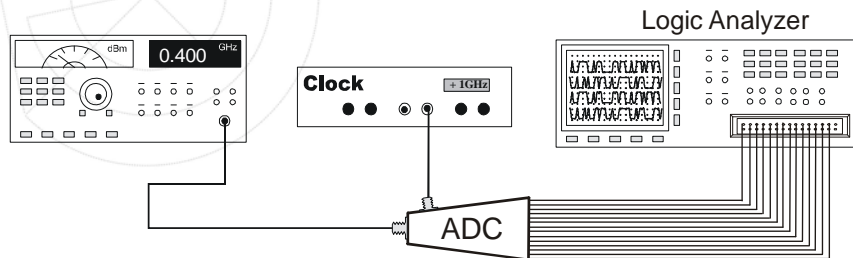

Analysis of the bit-sequence in a digital system

Presentation Outline

1. Introduction
2. Typical Instrumentation
3. The Role of Signal Excitation
4. Software Defined Radio Schemes
5. Some Real World Applications

3. The Role of Signal Excitation

A nonlinear system do not follow the superposition theorem, thus the response to a certain input, can not be found from the superposition of any other input's.

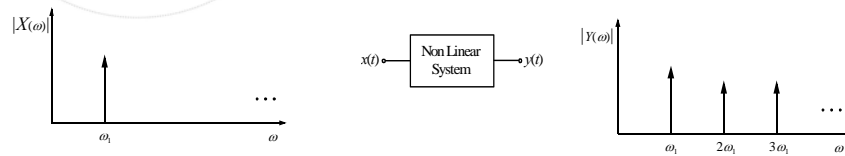

3. The Role of Signal Excitation

A nonlinear system do not follow the superposition theorem, thus the response to a certain input, can not be found from the superposition of any other input's.

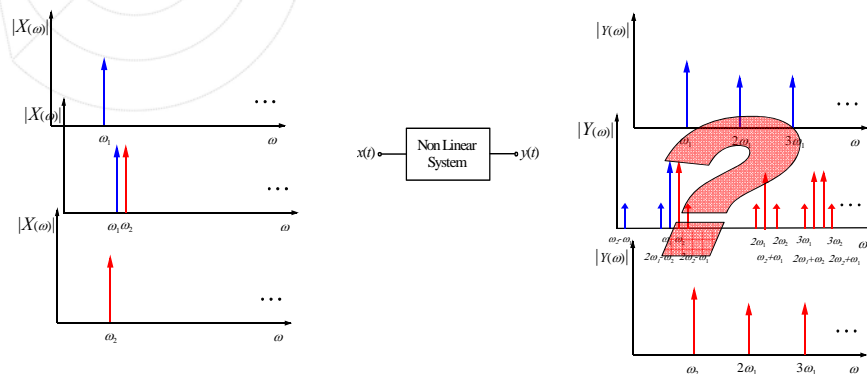

3. The Role of Signal Excitation

The best test signal to use in a nonlinear system is thus the real telecommunications signals from where the system will be excited.

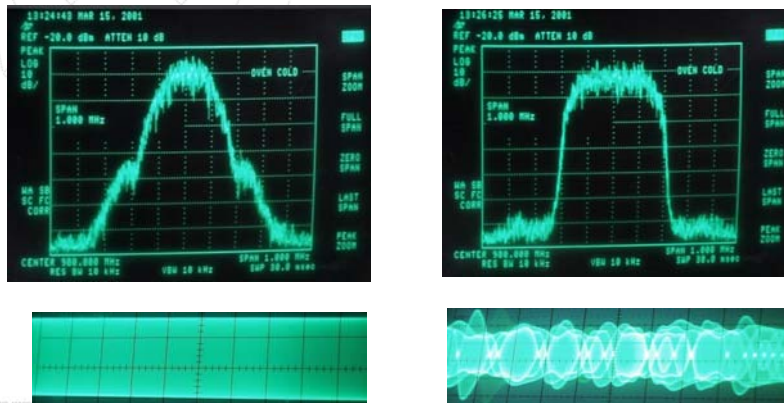

1. Introduction

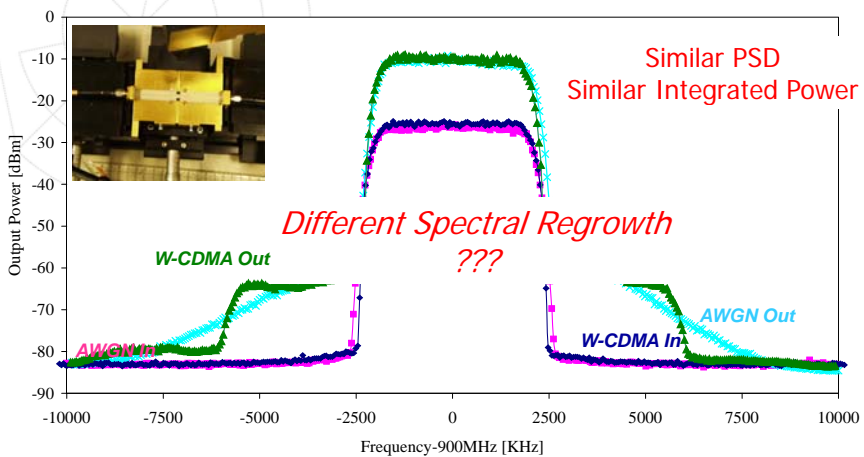

3. The Role of Signal Excitation

What should be the excitation used for wireless system characterization ?

- One single sinusoid (One tone ?)
- Two signal sinusoids (Two tones ?)
- Gaussian Noise ?
- Multisine Signals ?
- Other type of signals ?

3. The Role of Signal Excitation

One single sinusoid normally called one tone

$$A \cos(\omega t)$$

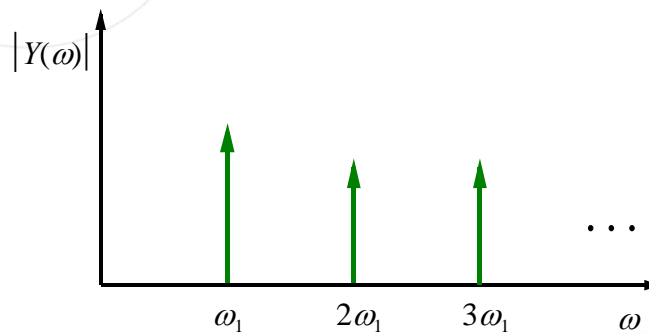

3. The Role of Signal Excitation

In Linear systems a one tone is enough for its characterization

$$H(j\omega) = |H(j\omega)| e^{j\phi(j\omega)}$$

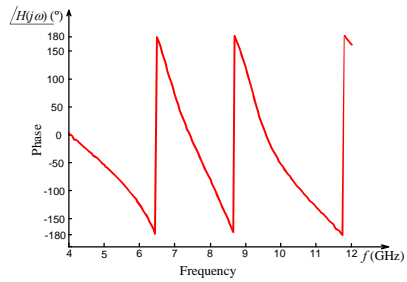
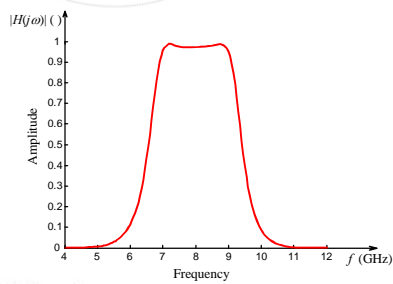
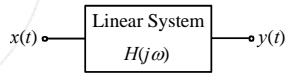

3. The Role of Signal Excitation

In nonlinear systems the same approach can be followed for a constant input power, changing the input power implies that the transfer function will also change with input amplitude, transforming itself into the Sinusoidal Input Describing Function

$$H(A, j\omega)$$

Which is now dependent both on the frequency and on the input power.

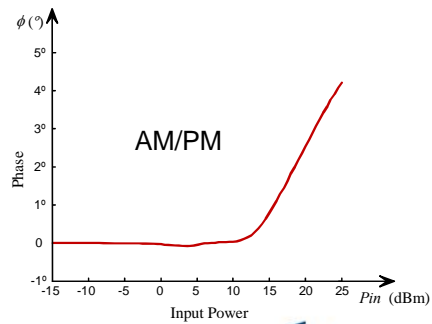
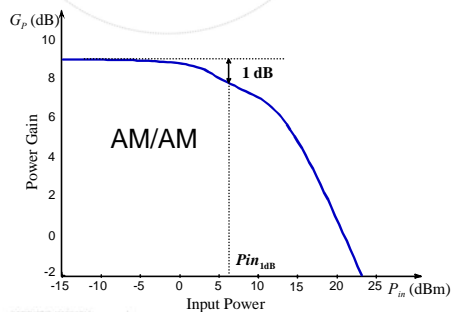

3. The Role of Signal Excitation

But the previous measurement only takes into account the change of the carrier with the input signal power and frequency.

Nevertheless the nonlinear system will generate harmonic distortion, that can be accounted for by:

Total Harmonic Distortion - THD

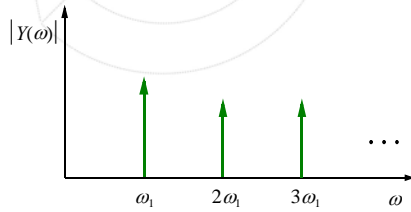

$$THD = \frac{\sqrt{\frac{1}{T} \int_0^T \left[\sum_{r=2}^{\infty} A_{or}(\omega, A_i) \cos[r\omega t + \phi_{or}(\omega, A_i)] \right]^2 dt}}{\sqrt{\frac{1}{T} \int_0^T [A_{o1}(\omega, A_i) \cos(\omega t + \phi_{o1}(\omega, A_i))]^2 dt}}$$

3. The Role of Signal Excitation

This type of measurement only takes into account the change of the carrier with the input signal power and frequency.

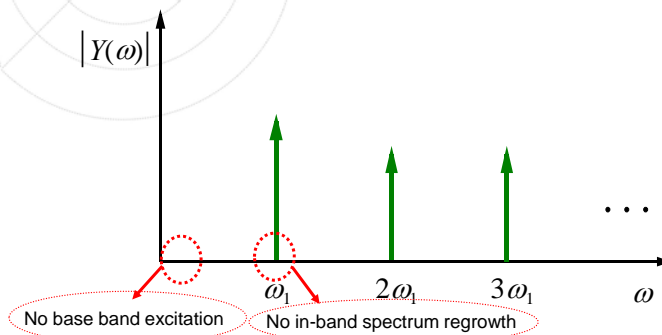

3. The Role of Signal Excitation

In summary a one tone test can:

- ❖ *Measure the gain compression and the phase deviation (Sinusoidal Describing Function)*
- ❖ *Measure the degree of harmonic distortion*

Can not:

- ❖ *Present any in-band spectral regrowth*
- ❖ *Excite base band components*

3. The Role of Signal Excitation

In this case the input signal consists in:

$$x(t) = A_{i1} \cos(\omega_1 t) + A_{i2} \cos(\omega_2 t)$$

And the output will be:

$$y_{NL}(t) = \sum_{r=1}^{\infty} A_{o,r} \cos(\omega_r t + \phi_{o,r}) \quad \text{where } \omega_r = m\omega_1 + n\omega_2 \quad \text{and } m, n \in \mathbb{Z}$$

This will allow to account for the same goals as the one tone as well as for other important in-band studies.

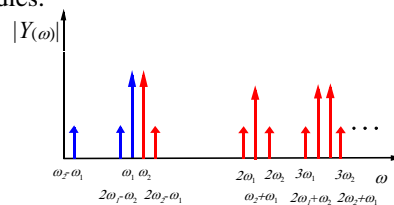

3. The Role of Signal Excitation

Power sweeps are very important in a two tone test, since they allow us to gather important IMD information, specially for small signal, as the well known IP3 or IPn.

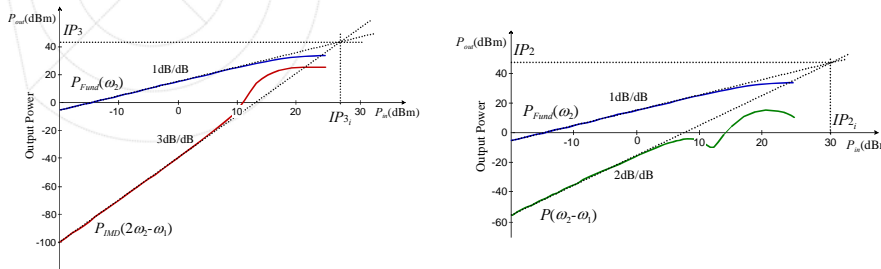

$$IMR \equiv \frac{P_{fund}}{P_{IMD}} = \frac{P(\omega_1)}{P(2\omega_1 - \omega_2)} = \frac{P(\omega_2)}{P(2\omega_2 - \omega_1)}$$

Nevertheless only a small step was done in the process of real signal approximation.

3. The Role of Signal Excitation

Only a single frequency at the base band is excited for each separation of tones. If the system is dynamic, then it can be studied by doing a sweep in tone separation, *but again we hope that the superposition theorem works....*

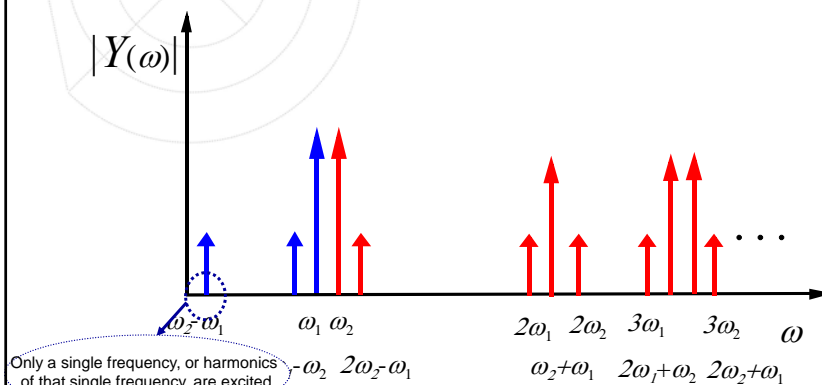

Only a single frequency, or harmonics of that single frequency, are excited

3. The Role of Signal Excitation

In summary a two tone test can:

- ❖ *Beyond the one tone information*
- ❖ *Measure the two tone input describing function*
- ❖ *Obtain in-band distortion information*
- ❖ *Excite the long term memory effects at a predetermined frequency*

Can not:

- ❖ *Fully excite the long term memory effects*
- ❖ *Present different peak envelope values*

3. The Role of Signal Excitation

A very popular test for nonlinear dynamic systems is the multisine approximation.

$$x(t) = \sum_{q=1}^Q A_q \cos(\omega_q t + \theta_q) \quad \text{e.g. for} \quad \omega_q = \omega_0 + (q-1)\Delta\omega$$

In this case not only the amplitude and the separation of tones is important as also the phase of each tone can generate a completely different signal.

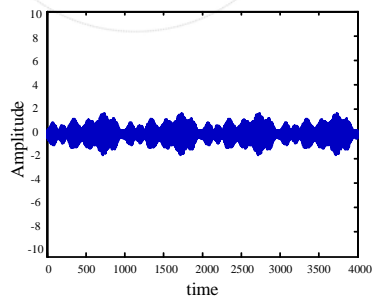

10 Tones of Randomized Phase

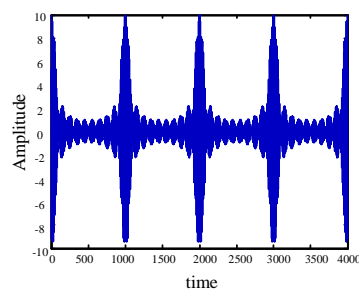

10 Tones of Equal Phase

3. The Role of Signal Excitation

In this case the output will be a combination of all the input tones:

$$y(t) = \sum_{r=1}^R A_r \cos(\omega_r t + \phi_r)$$

where $\omega_r = m_0\omega_0 + \dots + m_q\omega_q + \dots + m_{Q-1}\omega_{Q-1}$, $|m_0| + \dots + |m_q| + \dots + |m_{Q-1}| \leq \text{Order}_{Max}$

A typical output signal is:

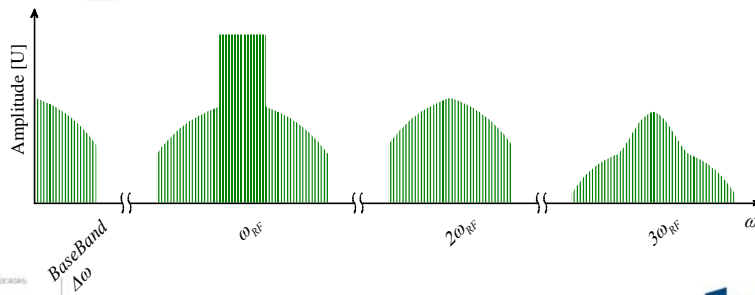

3. The Role of Signal Excitation

The in-band signal will allow us to evaluate the **spectral regrowth** content and thus study the **Adjacent Channel Power Ratio, ACPR**, or the **Noise Power Ratio, NPR**.

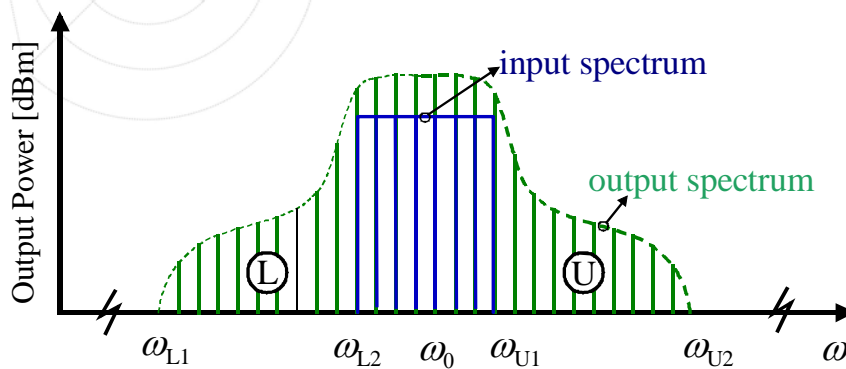

3. The Role of Signal Excitation

In the base band a carefully selection of tone spacing should be done in order to excite the most important characteristics of the system.

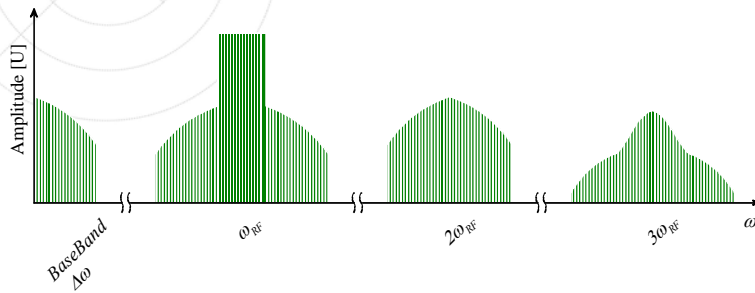

3. The Role of Signal Excitation

In summary a multisine test can:

- ❖ *Beyond the two tone information*
- ❖ *Excite the long term memory effects*

We should be careful in:

- ❖ *Defining the number of tones and tone separation*
- ❖ *Defining the relative phase between tones*

3. The Role of Signal Excitation

Despite those frequency discrete excitation, continuous signals were also used, for instance the white Gaussian noise. First attempts of formal nonlinear dynamic system identification led to some important conclusions:

- 1 – A test with white Gaussian noise is enough to gather all behavioral information necessary to extract a full nonlinear dynamic model of fading memory [Schetzen, 1980].
- 2 – The non-periodicity of noise stimuli pose several problems on the use of modern digital signal processing techniques. Thus, periodic signals are preferred.
- 3 – Fortunately it was already shown that the response to noise signals can be imitated by several randomized realizations of a periodic multisine [Schouckens & Pintelon, 2001].
- 4 – Several authors are now questioning the validity of the Gaussian excitation for device testing [Apparin, 2001].

3. The Role of Signal Excitation

Probability Density, $pdf_x(x)$, as a Weighting Function

Since typical laboratory data like Output Power, Power Spectrum, etc., is averaged in nature:

$$P_{in} = E\{x(s)^2\} = \int_{-\infty}^{\infty} x^2 pdf_x(x) dx$$

$$P_{out} = E\{y(s)^2\} = \int_{-\infty}^{\infty} y^2 pdf_y(y) dy = \int_{-\infty}^{\infty} f_{NL}(x)^2 pdf_x(x) dx$$

it is intuitive to expect that, more important than the trajectory of amplitude values assumed by the excitation, $x(t)$, should be the *Probability* with which each value is reached, i.e., the excitation $pdf_x(x)$ or $ccdf_x(x)$.

3. The Role of Signal Excitation

Probability Density, $pdf_x(x)$, as a Weighting Function

That conclusion led several engineers to abandon the *Peak-to-Average Ratio* as a faithful excitation metric for predicting output system distortion;

and led manufacturers of waveform generators to give information of the signal complementary cumulative distribution function, $ccdf_x(x)$.

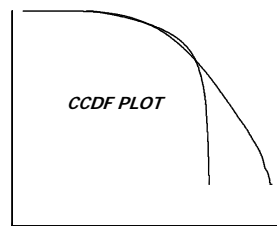

3. The Role of Signal Excitation

Multisines for Memoryless Nonlinear Systems

To prove this role of the $pdf_x(x)$ we tested a nonlinear system with three signals of equal integrated power but distinct amplitude distribution:

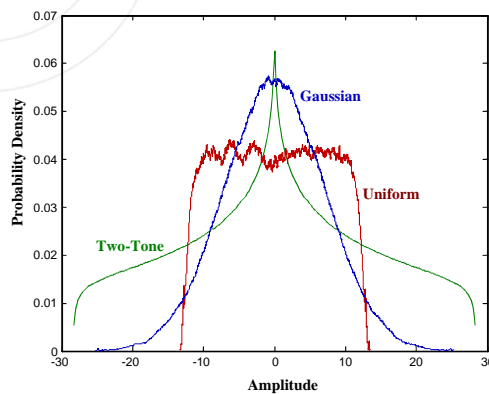

3. The Role of Signal Excitation

Different modulated signals impose different statistical behavior, and thus should be dealt accordingly.

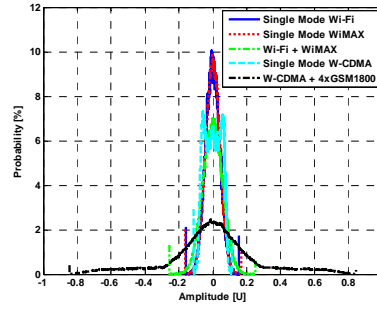
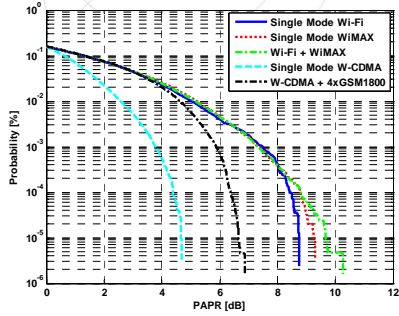

Presentation Outline

1. Introduction
2. Typical Instrumentation
3. The Role of Signal Excitation
4. Software Defined Radio Schemes
5. Some Real World Applications

4. Software Defined Radio Schemes

Software Defined Radio

Implement radio functionality as software modules running on a general purpose basic hardware;

Adaptable and Reconfigurable;

Moving as many of the radio functions from the RF transceiver to the baseband digital chip as possible will improve the radio performance, cut the overall power and, most importantly, allow reconfigurability of the radio designs for multi-band and multi-standard coexistence.

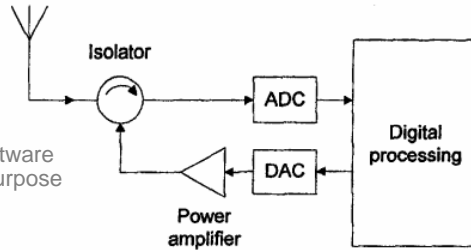

J. Mitola, "The software radio architecture," *IEEE Communications Magazine*, vol. 33, n° 5, pp. 26–38, May 1995

4. Software Defined Radio Schemes

From a Physical point of view the software radio concept is moving from the simple base band technological approach to the real RF signal evaluation.

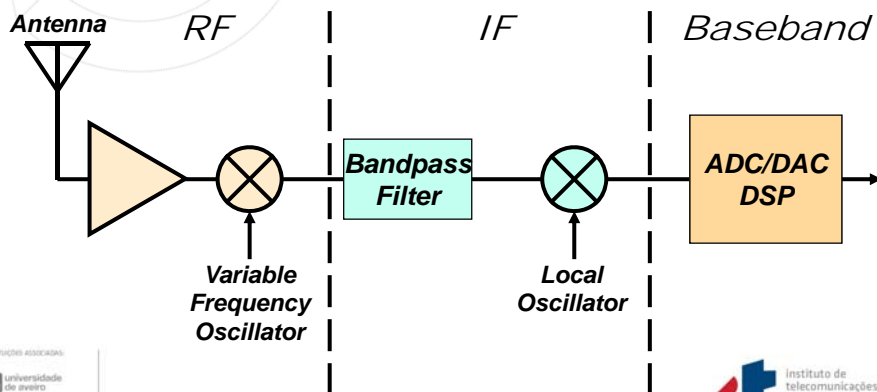

4. Software Defined Radio Schemes

From a Physical point of view the software radio concept is moving from the simple base band technological approach to the real RF signal evaluation.

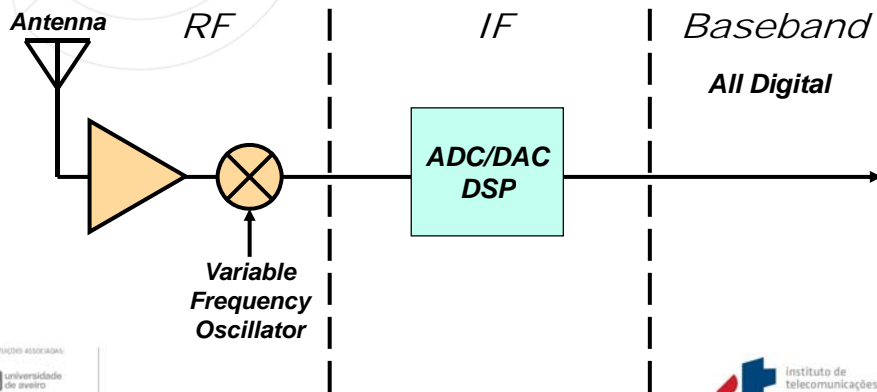

4. Software Defined Radio Schemes

From a Physical point of view the software radio concept is moving from the simple base band technological approach to the real RF signal evaluation.

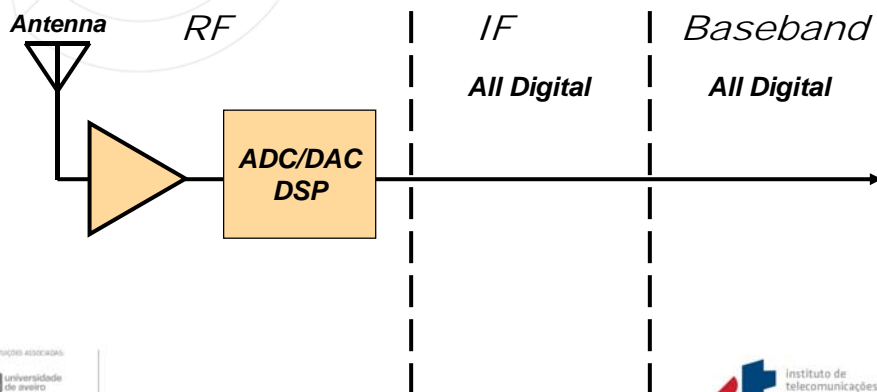

4. Software Defined Radio Schemes

SDR approaches imply the use of ADC's and DAC's for the conversion between domain modes.

So analog and digital figures of merit should be measured and co-exist in this type of SDR approaches.

For instance in a receiver we have:

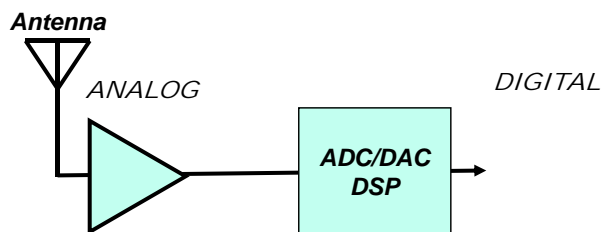

4. Software Defined Radio Schemes

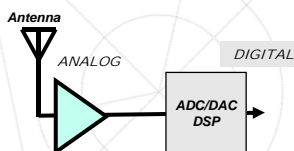

The Analog Part includes an Amplifier and sometimes a tuned filter.

Thus Figures of merit like:

Noise Figure

Bandwidth

Input VSWR

Gain

IMD, IP3

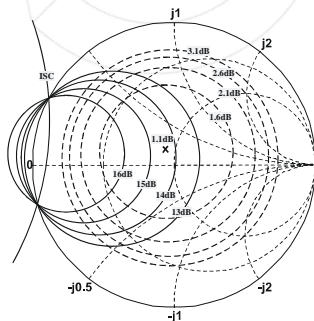

4. Software Defined Radio Schemes

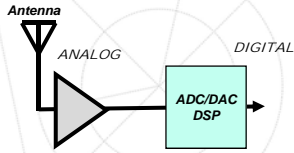

Converters like ADC's and DAC's impose different types of Figures of merit like:

Static Gain and Offset

Integral and Differential Nonlinearity, Monotonicity

Hysteresis, Harmonic and Spurious Distortions, Total Harmonic Distortion

SFDR, SINAD, IMD

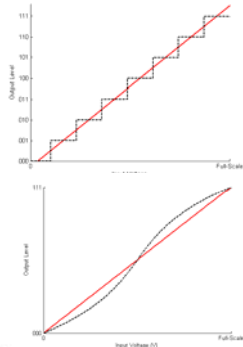

4. Software Defined Radio Schemes

Most of these figures of merit can be measured using combinations of analog and digital instrumentation such as:

- Vector Signal Analyzers (either Analog and Digital)
- Oscilloscopes
- Logic Analyzers

Nevertheless these instruments are stand alone, and many of them allow power measurements but not phase.

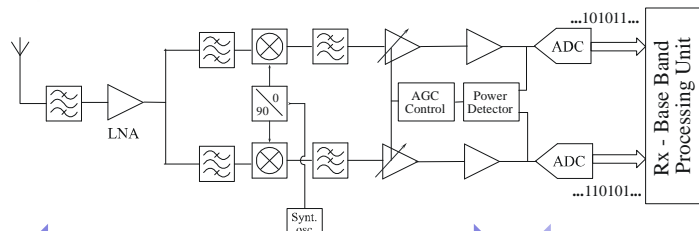

4. Software Defined Radio Schemes

Most of these figures can be measured using combinations of analog and digital instrumentation

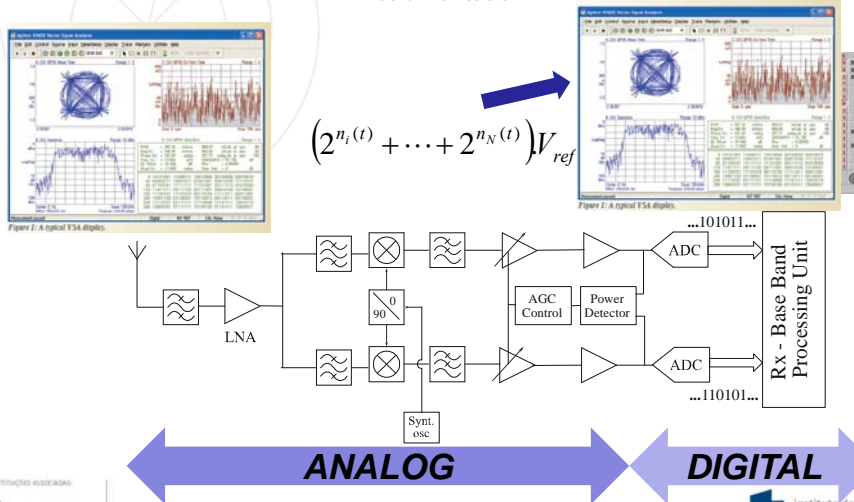

4. Software Defined Radio Schemes

The mixed mode signal analyzer is a viable solution for the complete analysis of SDR solutions.

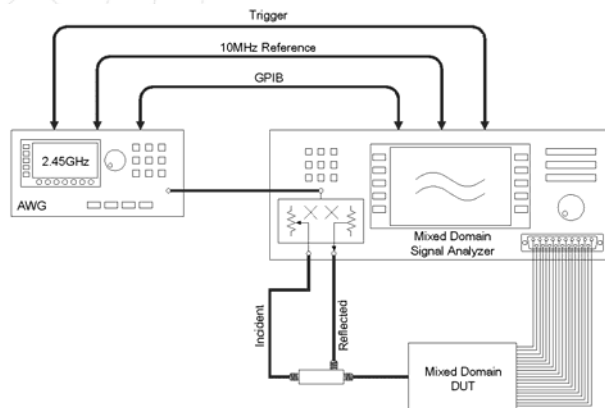

4. Software Defined Radio Schemes

Synchronous input and output samplers:

- *One in the analog domain*
- *Other at the digital domain*

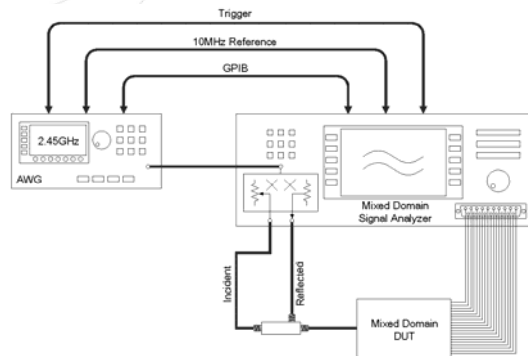

4. Software Defined Radio Schemes

Usual figures of merit could continue to be measured

$$\rho(\omega) = \frac{V_{ref}(\omega)}{V_{inc}(\omega)} = S_{11D}(\omega)$$

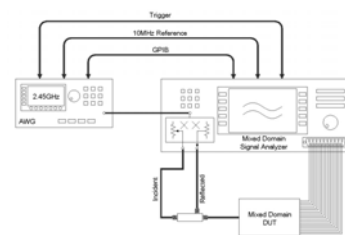

$$H_L(\omega) = \frac{V_{dig}(\omega)}{V_{inc}(\omega)} = \frac{\frac{1}{T} \int_{-T/2}^{T/2} [2^{n_i(t)} + \dots + 2^{n_N(t)}] \cdot V_{ref} \cdot e^{-j\omega t} dt}{\frac{1}{T} \int_{-T/2}^{T/2} v_{inc}(t) \cdot e^{-j\omega t} dt}$$

4. Software Defined Radio Schemes

Using typical laboratory measurement instruments:

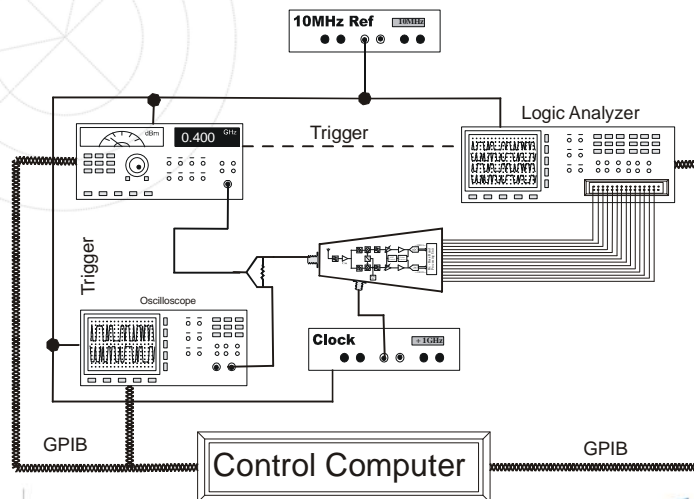

Presentation Outline

1. Introduction
2. Typical Instrumentation
3. The Role of Signal Excitation
4. Software Defined Radio Schemes
5. Some Real World Applications

SDR System Characterization

5. Some Real World Applications

First test: Sine wave excitation

Measure the amplitude gain and phase over frequency

Measure the AM/AM and AM/PM by characterizing the amplitude gain and phase over input power sweep

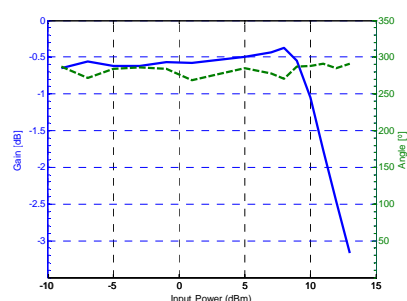
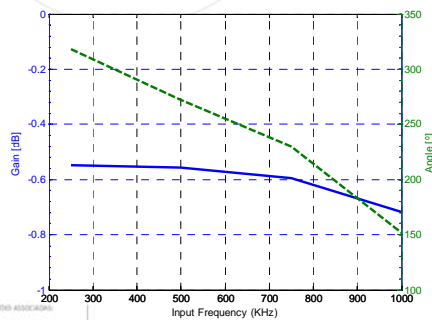

5. Some Real World Applications

Second test: Two-tone excitation

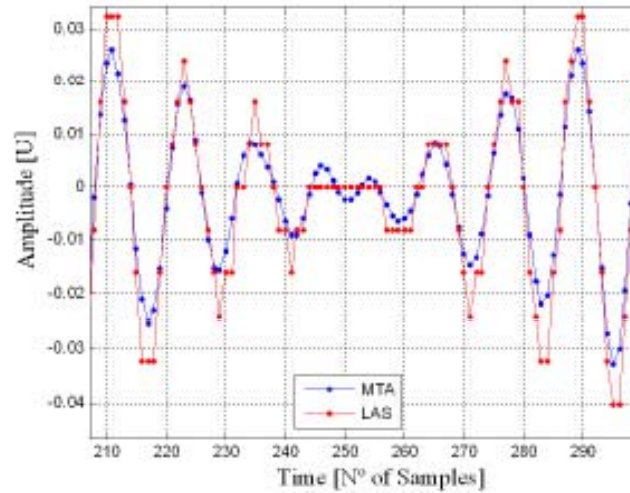

Interference Measurements

Interference at airport frequency: 118.1 MHz

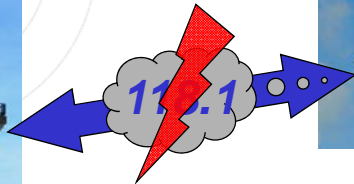

Lisbon airport reports:

Control tower frequency: 118.1 MHz **highly interfered!**
Airways controllers hear a broadcast radio station on the
airport-plane audio frequency.

That frequency channel becomes unavailable!

For security reasons other frequency channel starts to be
used..



What can be done?



Possible problems

Interference possible sources

Complex analysis

- Huge amount of licensed radio communications services
- Huge amount of free radio services (Wi-Fi, Bluetooth, RFID's, ...)
- Illegal use of spectrum
- Other sources (microwave ovens, TV amplifiers that become unstable, ...)



We should measure:

- A correct characterization of the bandwidth, power, should be measured
- Obtain the maximum information about the interfered signal, what happens as alarm reports, 'drop calls', etc.

Measurement procedure

Spectrum Monitoring

Interference Characterization

- **Occupied Bandwidth**
- **Interference Duration** (*permanent, intermittent, random, ...*)
- **Occurred period** (*weather conditions, temperature, humidity, rain, etc.*)
- **Power** (*allow us to predict the distance to the source*)
- **Signal Demodulation** (*viable in analogue systems*)



Airport problem

We already know much about the interference...
Is permanent (allows the location more efficiently)



In the demodulation procedure, we can conclude that it is an analogue signal, and a radio broadcast station, which we will call "**A RADIO**", which is licensed to broadcast at frequency channel **104.3 MHz**

Since no transmission is been done at that channel from the radio operator, we are in presence of a **Nonlinear Distortion Problem**, that is a signal that is generated in a nonlinear device, using the 104.3MHz channel as one of the mixed signals.

Intermodulation Interference

Available information from the measurements:

"**A RADIO**" – 104.3 MHz (identified due to the interfered signal demodulation)

"**B RADIO**" - ? (unknown)

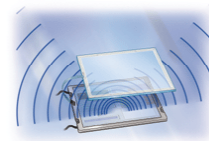

- **Solution:** Use "A Radio" channel frequency as a un modulated carrier.
- Try to demodulate the interference channel, where we can hear "**B RADIO**", which is identified as the one that transmits at **90.4 MHz** (and is installed in the same tower in adjacent antennas).

Using a third order mixing product:

$$2 \times 104.3 - 90.4 = 118.2 !!$$

Intermodulation Interference

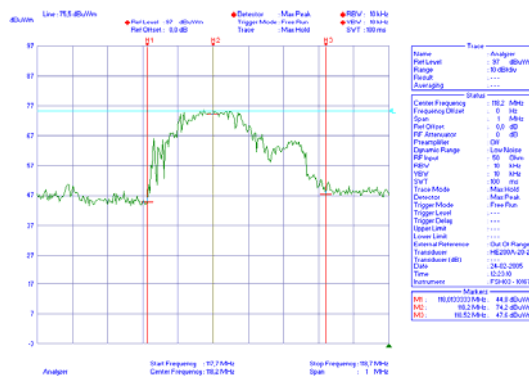

Trace	
Name	-Analysis
RefLevel	20 dBm
Range	30 dB
Start	---
Averaging	---
Status	
Center Frequency	18.25 MHz
Frequency Span	0.10 MHz
Span	0.10 MHz
Ref Offset	0.00 dB
FF Attenuator	0.00 dB
Phase Noise	Off
Dynamic Range	Line Noise
RF Power	50.00 dBm
RBW	10.00 kHz
VBW	30.00 kHz
TVT	300.00 dB
Trace Mode	Max Hold
Detector	Max Peak
Trigger Mode	Free Run
Trigger Level	---
Trigger Delay	---
Upper Limit	---
Lower Limit	---
Reference Reference	Out Of Range
Transducer	H6200A (27.00)
Transducer (dB)	---
Date	24.02.2005
Time	12:23:08
Instrument	F30401-00876

INSTITUÇÕES ASSOCIADAS:

 Universidade de Aveiro

Instituto de telecomunicações

Cause: Passive Intermodulation (PIM)

Source of the problem:

Inferior Radiation Structure

Solution:

Change the antenna due to oxidation



5. Acknowledgements

Pedro Cruz
José Pedro Borrego

ANACOM



INSTITUIÇÕES ASSOCIADAS:
 universidade
de aveiro

 Instituto de
telecomunicações